

① SCALE: 1/4" = 1'-0"

②

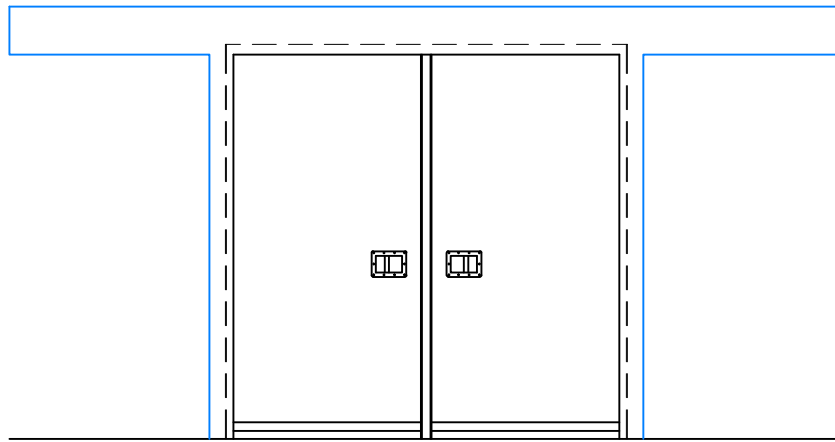

③ SCALE: 1/4" = 1'-0"

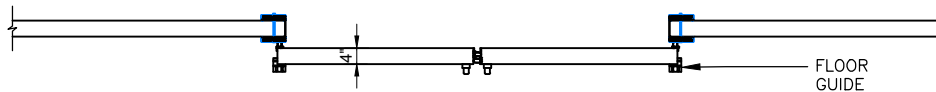

④ SCALE: 1/4" = 1'-0"

Bi-Parting Horizontal Electric Slide Door with Backup Casings and Cap Channels

Model EFD-BPHES

Bottom Door Guide

Exterior Pull Handle with Interior Recessed Handle

- ① ELEVATION – SWEEP BOTTOM BI-PARTING DOOR (EXTERIOR)
- ② SECTION – SWEEP BOTTOM BI-PARTING DOOR
- ③ ELEVATION – SWEEP BOTTOM BI-PARTING DOOR (INTERIOR)
- ④ JAMB – SWEEP BOTTOM BI-PARTING DOOR



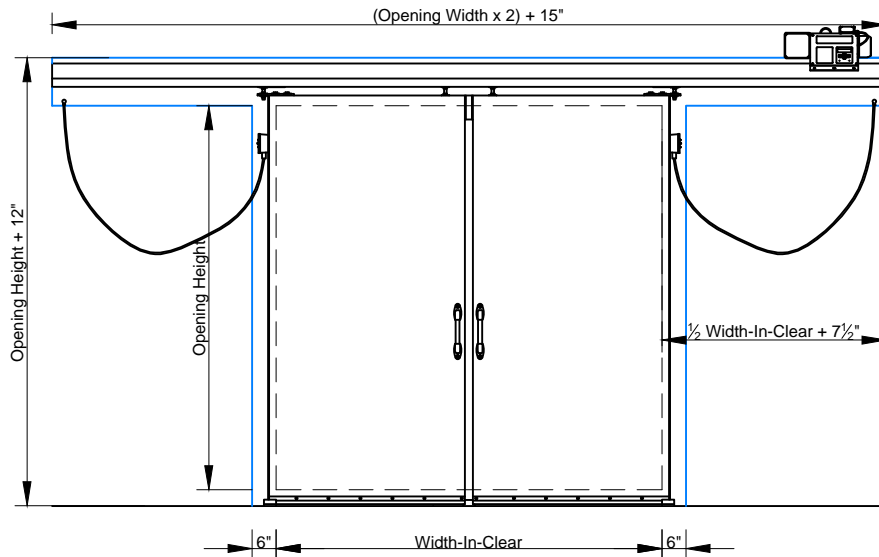

⑤ SCALE: 1/4" = 1'-0"

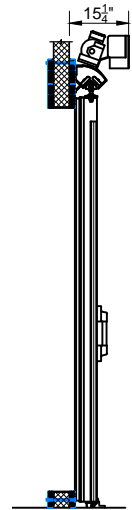

⑥

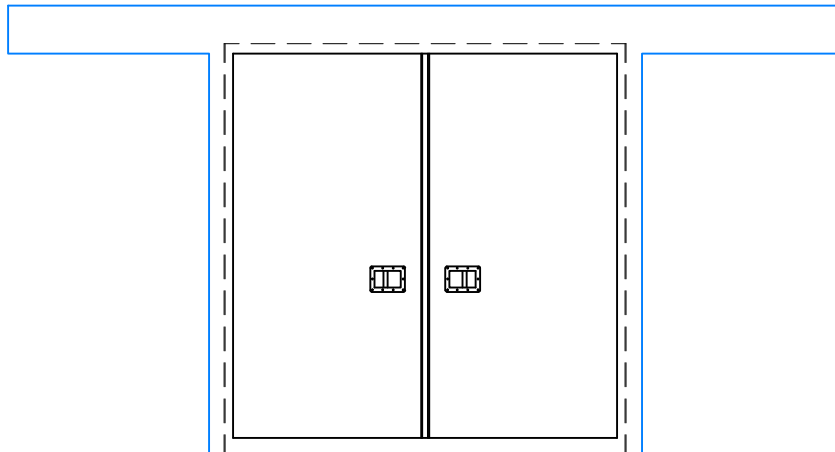

⑦ SCALE: 1/4" = 1'-0"

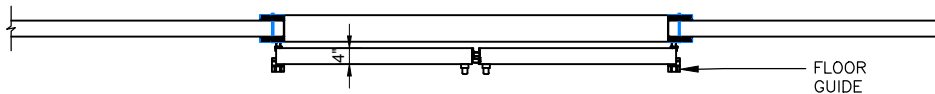

⑧ SCALE: 1/4" = 1'-0"

Bi-Parting Horizontal Electric Slide Door with Backup Casings and Cap Channels

Model EFD-BPHES

Bottom Door Guide

Exterior Pull Handle with Interior Recessed Handle

- ⑤ ELEVATION – HIGH SILL STEP OVER BI-PARTING DOOR (EXTERIOR)
- ⑥ SECTION – HIGH SILL STEP OVER BI-PARTING DOOR
- ⑦ ELEVATION – HIGH SILL STEP OVER BI-PARTING DOOR (INTERIOR)
- ⑧ JAMB – HIGH SILL STEP OVER BI-PARTING DOOR



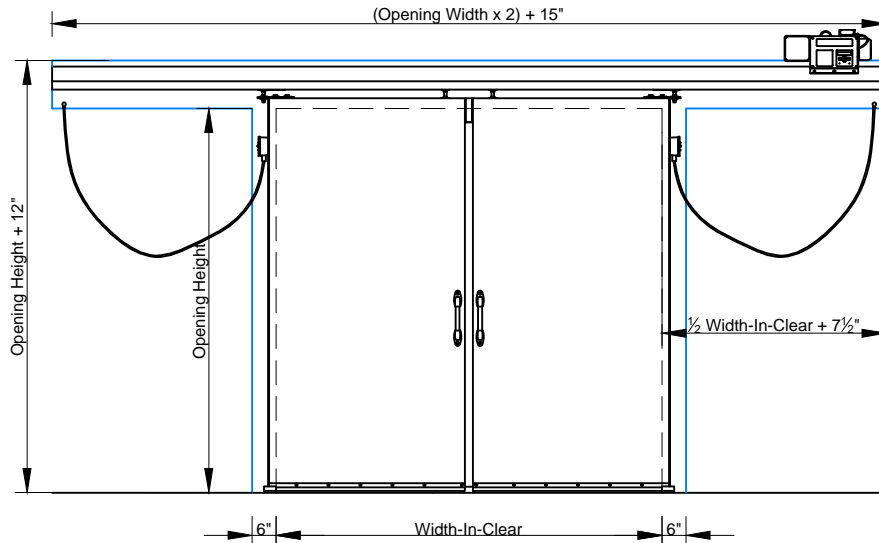

⑨ SCALE: 1/4" = 1'-0"

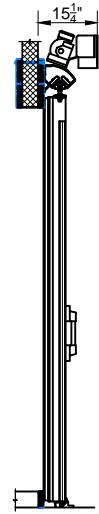

⑩

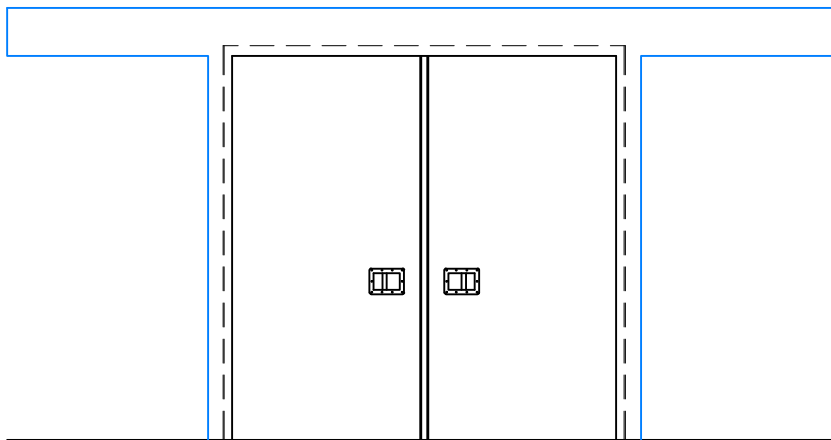

⑪ SCALE: 1/4" = 1'-0"

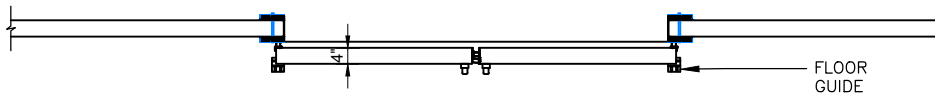

⑫ SCALE: 1/4" = 1'-0"

Bi-Parting Horizontal Electric Slide Door with Backup Casings and Cap Channels

Model EFD-BPHES

Bottom Door Guide

Exterior Pull Handle with Interior Recessed Handle

- ⑨ ELEVATION – HIGH SILL BI-PARTING DOOR (EXTERIOR)
- ⑩ SECTION – HIGH SILL BI-PARTING DOOR
- ⑪ ELEVATION – HIGH SILL BI-PARTING DOOR (INTERIOR)
- ⑫ JAMB – HIGH SILL BI-PARTING DOOR



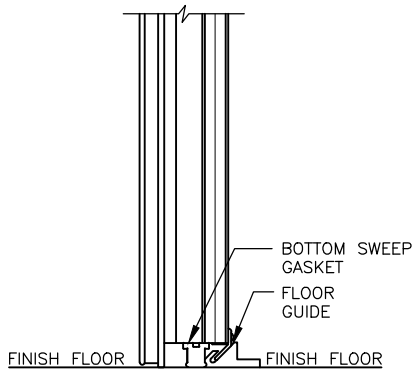

⑬ SCALE: 1" = 1'-0"

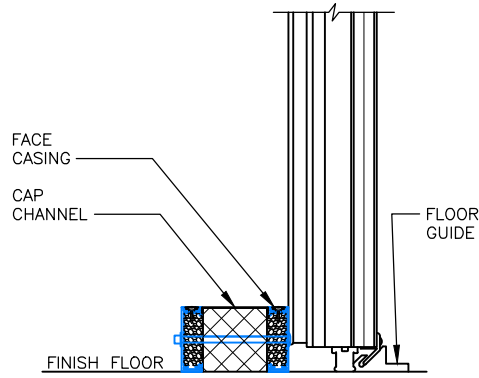

⑭ SCALE: 1" = 1'-0"

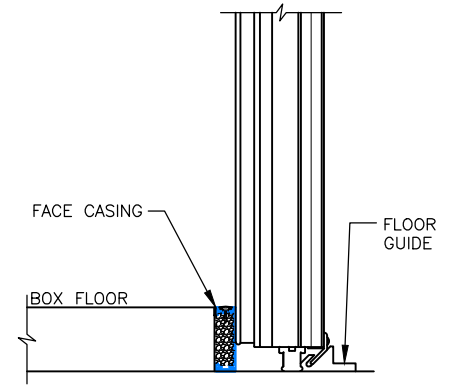

⑮ SCALE: 1" = 1'-0"

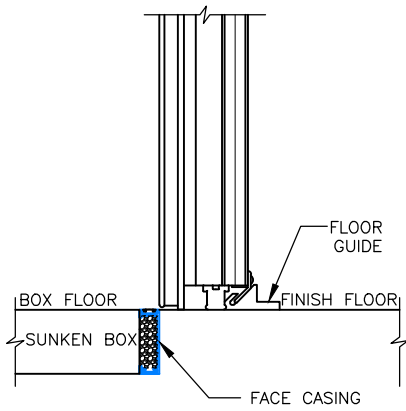

⑯ SCALE: 1" = 1'-0"

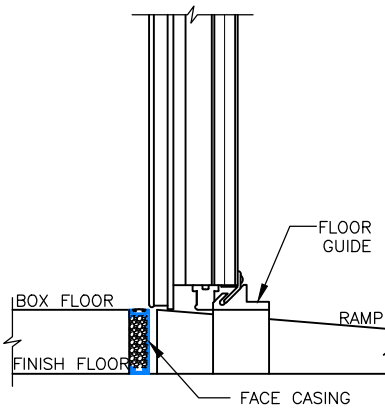

⑰ SCALE: 1" = 1'-0"

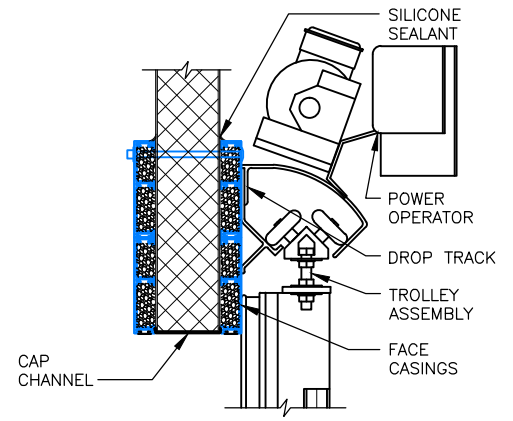

⑱ SCALE: 1" = 1'-0"

Bi-Parting Horizontal Electric Slide Door with Backup Casings and Cap Channels

Model EFD-BPHES

Bottom Door Guide

Exterior Pull Handle with Interior Recessed Handle

- ⑬ SILL DETAIL – SWEEP BOTTOM
- ⑭ SILL DETAIL – HIGH SILL STEP OVER
- ⑮ SILL DETAIL – HIGH SILL
- ⑯ SILL DETAIL – HIGH SILL WITH SUNKEN BOX FLOOR
- ⑰ SILL DETAIL – HIGH SILL WITH RAMP
- ⑱ HEAD – BI-PARTING DOOR – INSULATED METAL PANEL

